



Official Website



Company Wechat



NS/DNS SERIES USER MANUAL

GoodWe(China)
No.189 Kunlunshan Rd., SND,
Suzhou, 215163, China
T: 400 998 1212
service.chn@goodwe.com.cn
www.goodwe.com.cn

GoodWe(Netherlands)
Zevenwouden 194 .
3524 CX Utrecht, the Netherlands
T: +316 1988 6498
service.nl@goodwe.com.cn
www.goodwe.com.cn

GoodWe(Australia)
19 Fairleigh Street, Glenroy,
VIC, 3046, Australia
T: +613 9324 0559
service.au@goodwe.com.cn
www.goodwe.de

GoodWe(UK)
46 Foyle Road London
N17 ONL United Kingdom
T:+ 44 (0)333 358 3184
service@goodwe.co.uk
www.goodwe.com.cn

Note: The contact information above is subject to change without notice. please refer to the company's website at www.goodwe.com.cn.

340-00007-03



SOLAR INVERTER

1 Symbols	01
------------------	----

2 Safety	01
-----------------	----

3 Installation	
3.1 Mounting Instructions	02
3.2 Inverter Overview and Package	02
3.3 Inverter Installation	03
3.4 Electrical Connection	05











4 System Operation	
4.1 Indicator Lights	13
4.2 User Interface and Use of the Display.....	13
4.3 Error Code	16
4.4 Wi-Fi Reset and Reload to Factory Setting	17

5 Troubleshooting	17
--------------------------	----

6 Technical Parameters	18
-------------------------------	----

7 Certificates	23
-----------------------	----

1 Symbols

	Caution! Failure to observe a warning indicated in this manual may result in injury.		Components of the product can be recycled.
	Danger of high voltage and electric shock!		This side up; the package must always be transported, handled and stored in such a way that the arrows always point upwards.
	Danger of hot surface!		No more than six (8) identical packages may be stacked on each other.
	Product should not be disposed as household waste.		The package/product should be handled carefully and never be tipped over or slung.
	CE Mark		Keep dry; the package/product must be protected from excessive humidity and must be stored under cover.
	Signals danger due to electrical shock and indicates the time (5 minutes) to allow after the inverter has been turned off and disconnected to ensure safety in any installation operation.		

2 Safety

The NS/DNS series inverter of Jiangsu GoodWe Power Supply Technology Co. Ltd. (hereinafter referred to as GoodWe) strictly conforms to related safety rules in design and test. Safety regulations relevant to the location shall be followed during installation, commissioning, operation and maintenance. Improper operation may have a risk of electric shock or damage to equipment and property. (NS: Single-MPPT, Single-Phase; DNS: Dual-MPPT, Single-Phase)

- Installation, maintenance and connection of inverters must be performed by qualified personnel, in compliance with local electrical standards, regulations and the requirements of local power authorities and/or companies.
- To avoid electric shock, DC input and AC output of the inverter must be terminated at least 5 minutes before performing any installation or maintenance.
- The temperature of some parts of the inverter may exceed 60°C during operation. To avoid being burnt, do not touch the inverter during operation. Let it cool before touching it.
- Keep children away from inverter.
- Do not open the front cover of the inverter. Apart from performing work at the wiring terminal (as instructed in this manual), touching or changing components without authorization may cause injury to people, damage to inverters and annulment of the warranty.
- Static electricity may damage electronic components. Appropriate method must be adopted to prevent such damage to the inverter; otherwise the inverter may be damaged and the warranty annulled.

- Ensure the output voltage of the proposed PV array is lower than the maximum rated input voltage of the inverter; otherwise the inverter may be damaged and the warranty annulled.
- When exposed to sunlight, the PV array generates dangerous high DC voltage. Please operate according to our instructions, or it will result in danger to life.
- PV modules should have an IEC61730 class A rating.
- If the equipment is used in a manner not specified by the manufacturer, the protection provided by the equipment may be impaired.
- Completely isolate the equipment should : switch off the DC switch, disconnect the DC terminal, and disconnect the AC terminal or AC breaker.
- Prohibit inserting or pulling the AC and DC terminals when the inverter is electrified.

3 Installation

3.1 Mounting Instruction

- In order to achieve optimal performance, the ambient temperature should be lower than 45 °C.
- For the convenience of checking the LCD display and possible maintenance activities, please install the inverter at eye level.
- Inverters should NOT be installed near inflammable and explosive items. Any strong electro-magnetic equipment should be kept away from installation site.
- Product label and warning symbol shall be clear to read after installation.
- Please install inverter in the place where is not exposed to direct sunlight, rain and snow.

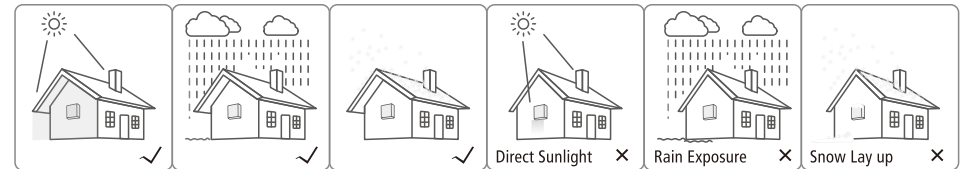

3.2 Inverter Overview and Package

Check the scope of delivery for completeness and any visible damage.

3.2.1 Inverter Overview

Appearance of NS Series 1-3KW refer to Figure3.2.1-1. Appearance of NS Series 3.6-5KW and DNS Series 3-5KW refer to Figure3.2.1-2.

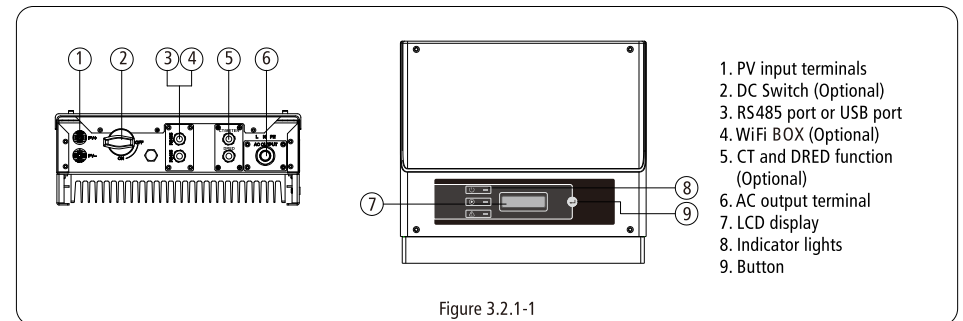

Figure 3.2.1-1

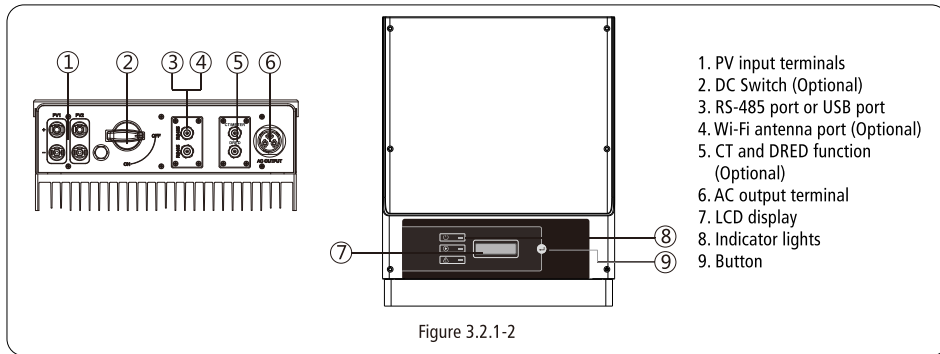
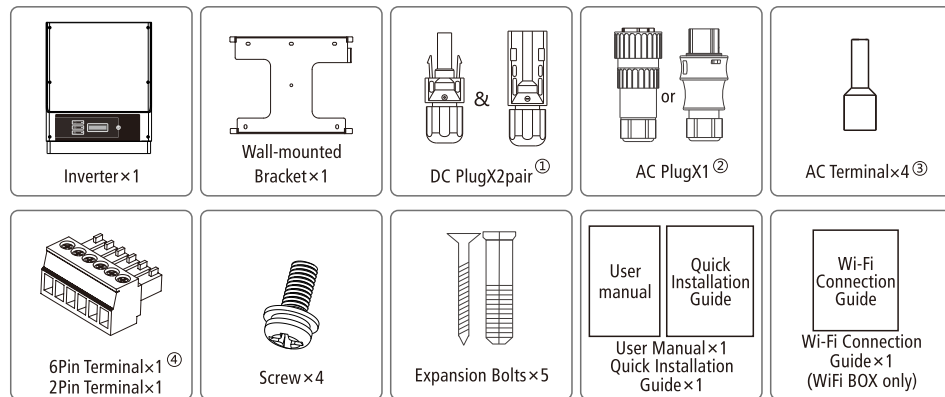

Figure 3.2.1-2

3.2.2 Package



- ① There is 1 pair of DC connectors in NS Series 1-3KW. and 2 pairs of DC connectors in NS Series 3.6-5KW and DNS Series 3-5KW ;
 ② AC Plug is applied to both NS Series 3.6-5KW and DNS Series 3-5KW;
 ③ AC terminal is applied to NS Series 1-3KW;
 ④ 6Pin terminal for RS485 function, 2Pin terminal for CT function.

3.3 Inverter Installation

3.3.1 Selecting the installation location

The following must be considered when selecting the best location for an inverter:

- The mount and installation method must be appropriate for the inverter's weight and dimensions.
- The location must be well ventilated and sheltered from direct sunlight.
- The inverter must be installed vertical or with a backward tilt less than 15°. No sideways tilt is allowed. The connection area must point downwards. Refer to Figure 3.3.1-1.

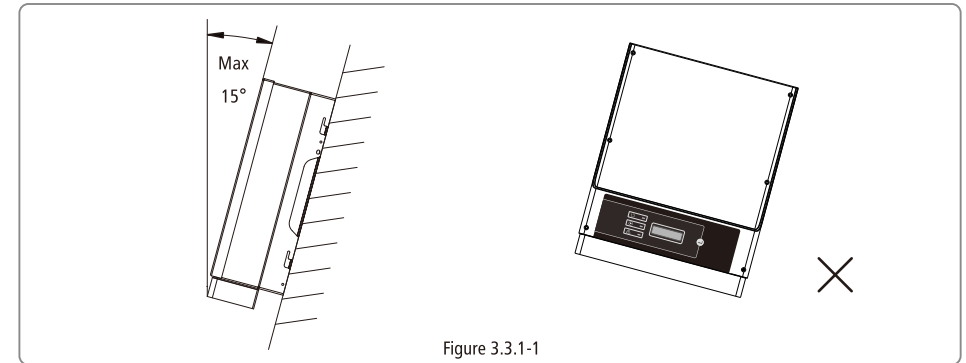

Figure 3.3.1-1

To allow dissipation of heat, and for convenience of dismantling, clearances around the inverter must be at least:

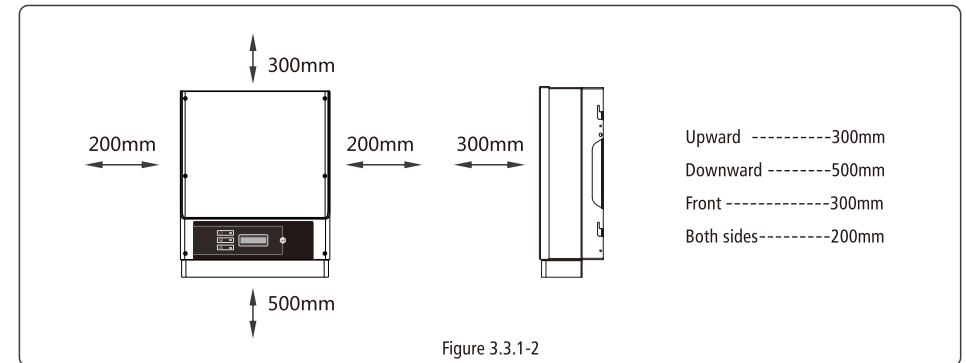

Figure 3.3.1-2

3.3.2 Mounting Procedure

- (1) Use the wall-mounted bracket as a template and drill holes in the wall, 10 mm in diameter and 80 mm deep. NS 1kW~3kW referred to Figure 3.3.2-1, NS 3.6kW~5kW & DNS 3kW~5kW referred to Figure 3.3.2-2.
- (2) Fix the wall mounting bracket on the wall using the expansion bolts in the accessories bag.
- (3) Hold the inverter by the side groove as Figure 3.3.2-3.
- (4) Install the inverter on the wall-mounted bracket. NS 1kW~3kW referred to Figure 3.3.2-4, 3.3.2-5. NS 3.6kW~5kW & DNS 3kW~5kW referred to Figure 3.3.2-6, Figure 3.3.2-7.

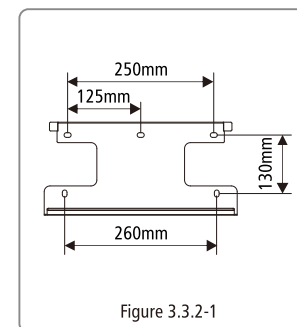

Figure 3.3.2-1

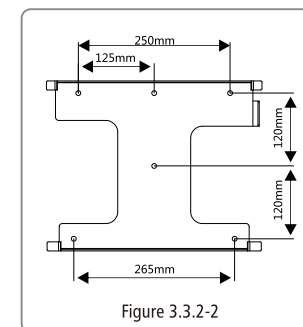

Figure 3.3.2-2

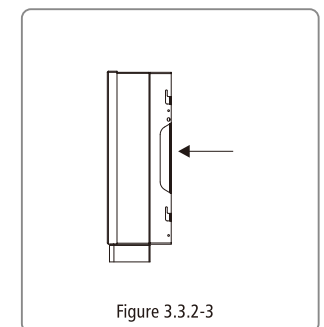

Figure 3.3.2-3

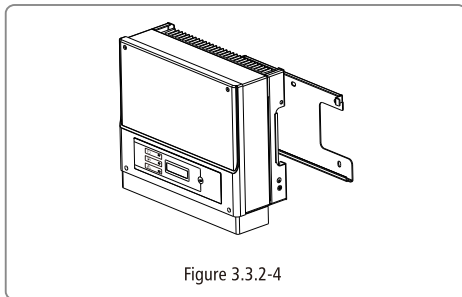

Figure 3.3.2-4

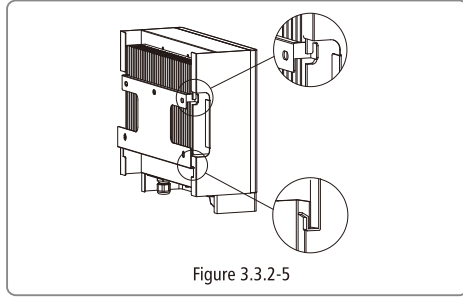

Figure 3.3.2-5

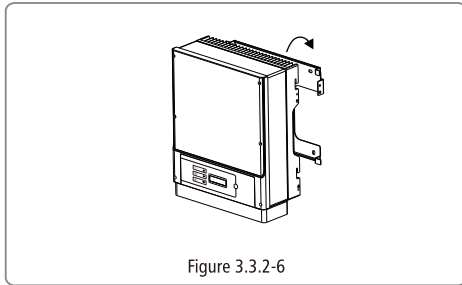

Figure 3.3.2-6

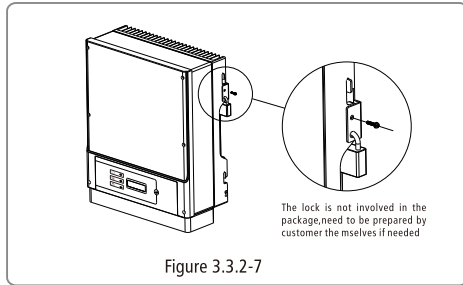



Figure 3.3.2-7

3.4 Electrical Connection

3.4.1 Connection to grid (AC side Connection)

- (1) Check the grid voltage and frequency if it can comply with the required voltage and frequency of inverter connection.
- (2) Add breaker or fuse to AC side, the specification should be more than 1.25 times of rated AC output current.
- (3) The PE line of inverter should be connected to the earth, make sure the impedance of neutral wire and earth wire less than 10 ohm.
- (4) Disconnect the breaker or fuse between the inverter and the utility.
- (5) Connect the inverter to the grid as follows:

Put the AC cable through the components in this order: screw cap, one-hole sealing ring, insulation body and sheet metal parts.
Installation method of NS Series 1-3KW please refer to Figure 3.4.1-1.

 Make sure the cable is connected well and can't be plugged out after connecting with AC terminals.

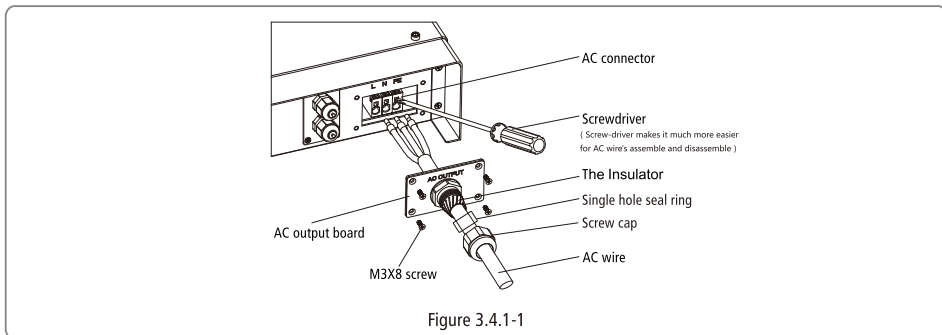

Figure 3.4.1-1

There are two AC connector brands for NS 3.6kW~5kW & DNS 3kW~5kW inverter, VACONN and WIELAND. Please refer to Figure 3.4.1-2.

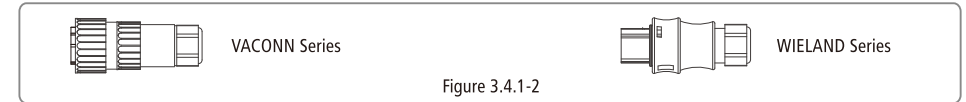

Figure 3.4.1-2

Installation instruction of VACONN series please refer to Figure 3.4.1-3.

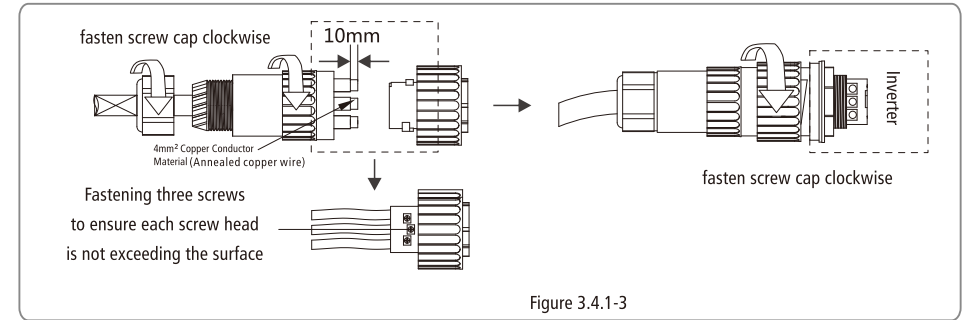

Figure 3.4.1-3

Installation instruction of WIELAND series please refer to Figure 3.4.1-4.

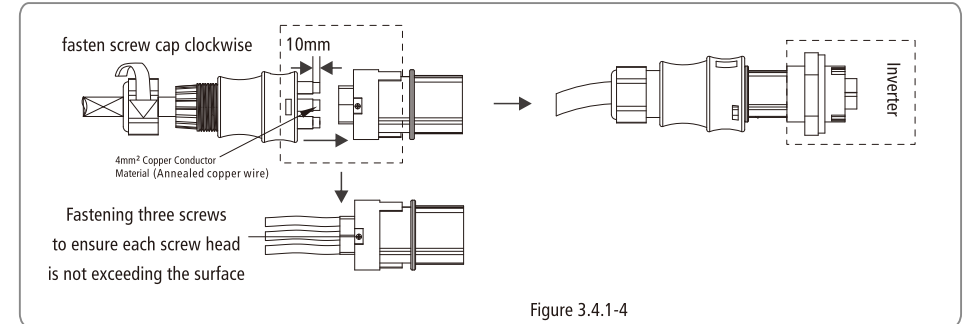

Figure 3.4.1-4

Cable specification of NS 1kW~3kW AC side is showed as Figure 3.4.1-5.

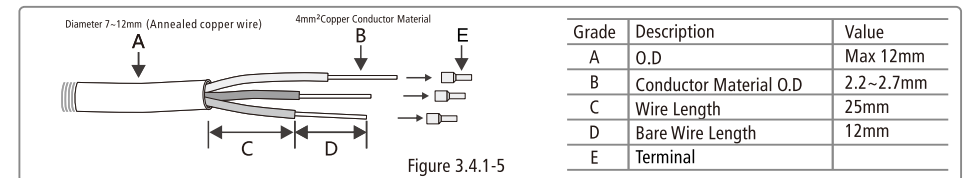

Figure 3.4.1-5

Cable specification of NS 3.6~5kW & DNS 3kW~5kW AC side please refer to Figure 3.4.1-6.

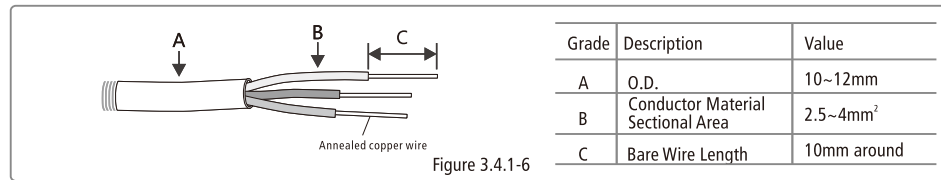

Figure 3.4.1-6

3.4.2 AC circuit breaker and leakage current protection device

In order to ensure that the inverter can be safe and reliable to disconnect from the power grid, please install an independent two pole circuit breaker to protect the inverter.

Inverter model	Recommended circuit breaker specifications
GW1000-NS/GW1500-NS/GW2000-NS/GW2500-NS	16A
GW3000-NS/GW3000D-NS/GW3600-NS/GW3600D-NS	25A
GW4200-NS/GW4200D-NS/GW5000-NS/GW5000D-NS	32A

Note: Multiple inverters are not allowed to share a circuit breaker.

The integrated leakage current detection device of the inverter can detect external leakage current in real time. When the detected leakage current exceeds the limit value, inverter will quickly disconnect with the grid. If the leakage current protection device is installed externally, the action current should be 300mA or higher.

3.4.3 DC Side Connection

- (1) Before connecting the PV strings, please ensure the plug connectors have the correct polarity. Incorrect polarity could permanently damage the unit.
- (2) The open circuit voltage of the PV strings cannot exceed the maximum input voltage of the inverter.
- (3) Only DC connectors provided by us are permitted to use.
- (4) The positive and negative pole is forbid to connect PE wire (Ground wire), otherwise, it will damage the unit.
- (5) Don't connect positive or negative pole of PV string to PE wire. Otherwise, it will cause damage to inverter.

There are three types of DC connectors, SUNCLIX / MC4 and AMPHENOL H4 series. Please refer to Figure 3.4.3-1.

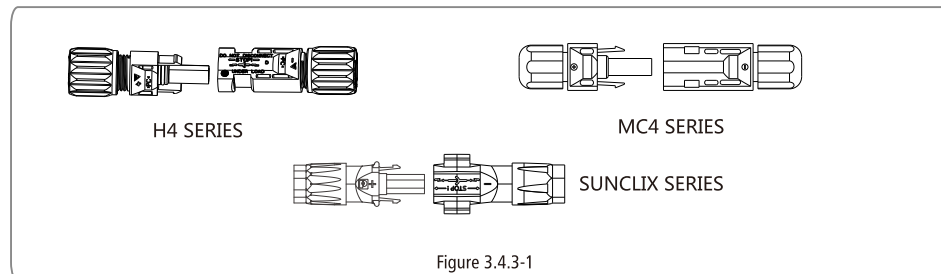

Figure 3.4.3-1

DC Cable specification is showed as Figure 3.4.2-2.

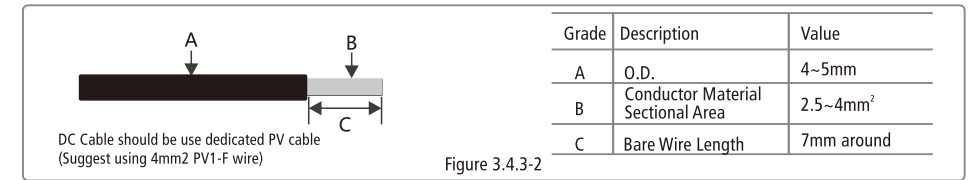

Figure 3.4.3-2

DC Cable should be use dedicated PV cable (Suggest using 4mm² PV1-F wire)

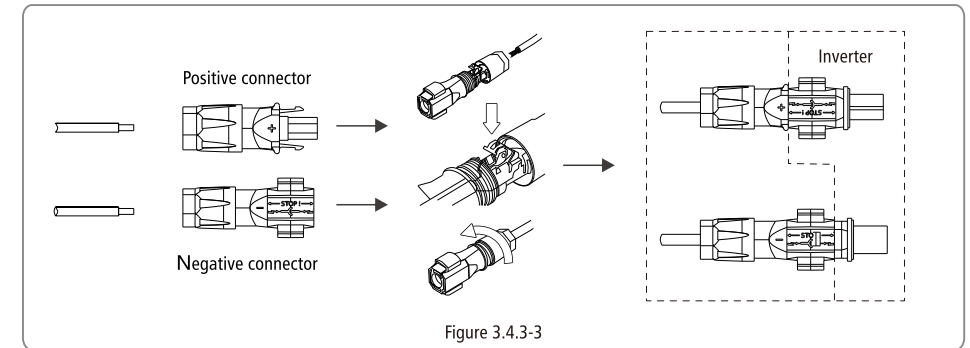

Figure 3.4.3-3

Installation instruction of MC4 and H4 Series please refer to Figure 3.4.3-4.

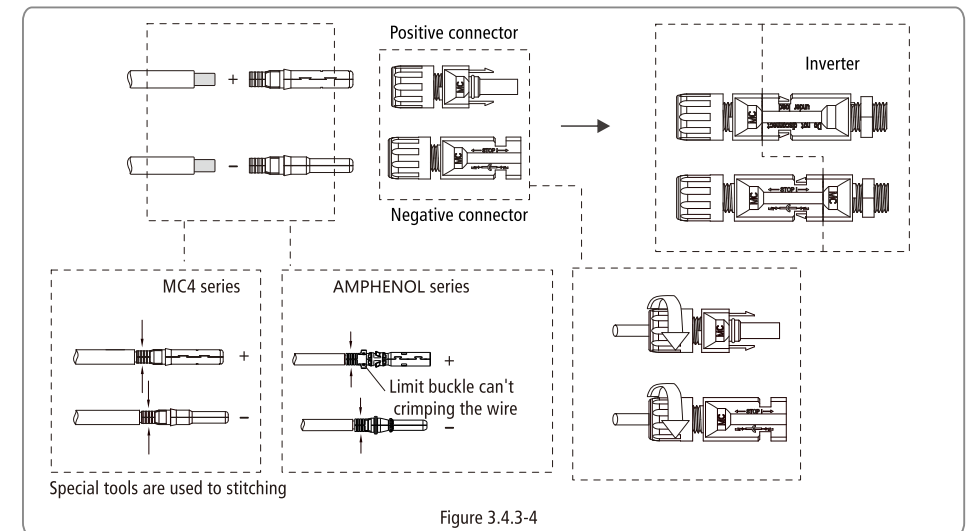

Figure 3.4.3-4

3.4.4 Earth Terminal Connection

The inverter is added earth terminal according to the requirement of EN 50178. It is must that installation person should connect the terminal to earthing wire.

Position of earth terminal as Figure 3.4.3-1.

The earth connecting terminal is on the side of inverter, illustrated as Figure 3.4.4-1. The customer should select to grounding base on site condition.

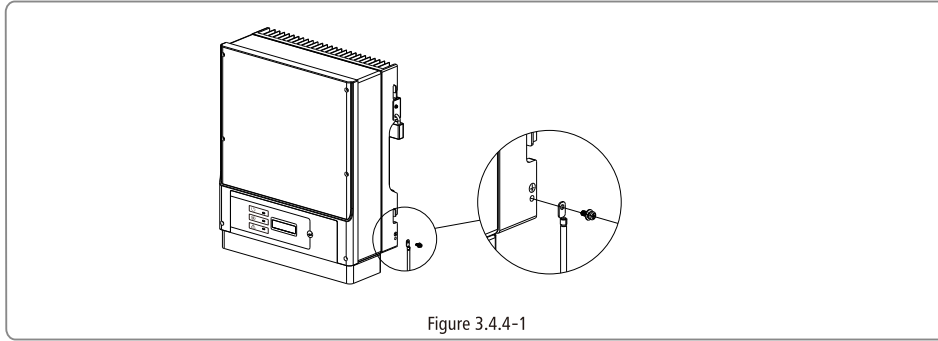

Figure 3.4.4-1

3.4.5 USB Communication

USB cable should be connected as Figure 3.4.5-1.

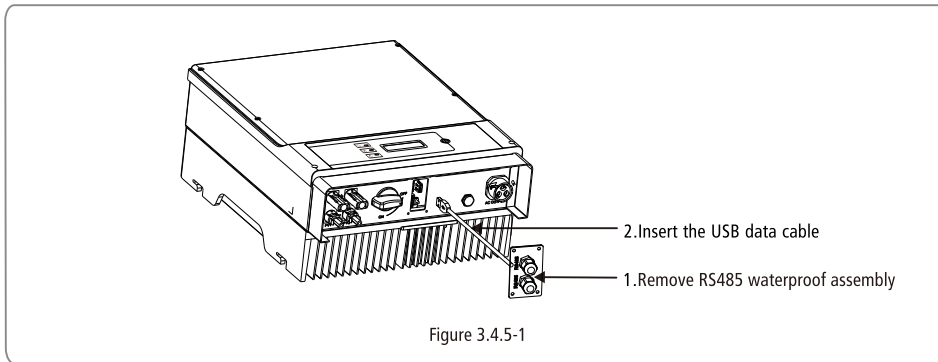

Figure 3.4.5-1

USB interface just for after-sales service team repair invter, shall not use the it for any other purposes..

3.4.6 RS485 Communication

This function is only applied to inverters with RS485.

The RS485 interface is used to connect EzLogger Pro and the maximum total length of all connecting cables should not exceed 800m. RS485 connection is referred to 3.4.6-1.

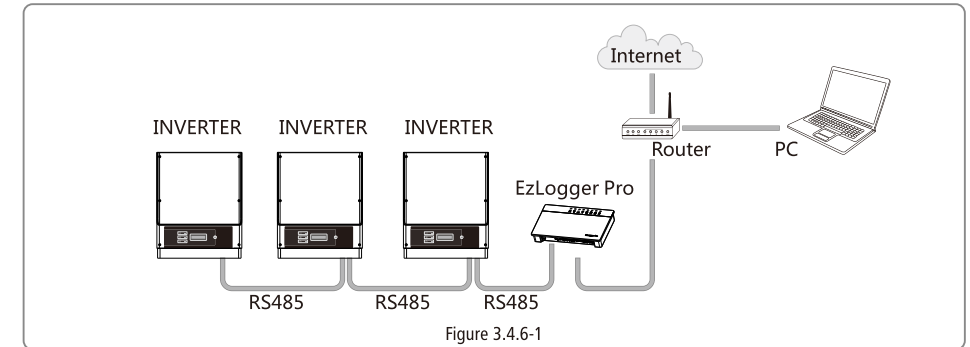

Figure 3.4.6-1

(1) Connection Procedure :

- Put the cable through the components in this order: screw cap, one-hole sealing ring, insulation body and sheet metal parts.
- Take the green terminal out of accessory bag. cable should be connected as Figure 3.4.6-2.
- Insert the green terminal into the corresponding interior terminal of the inverter. Pull cable softly to maintain the cable not to be pulled out.
- Lock the sheet metal parts onto the box and tighten the screw cap.

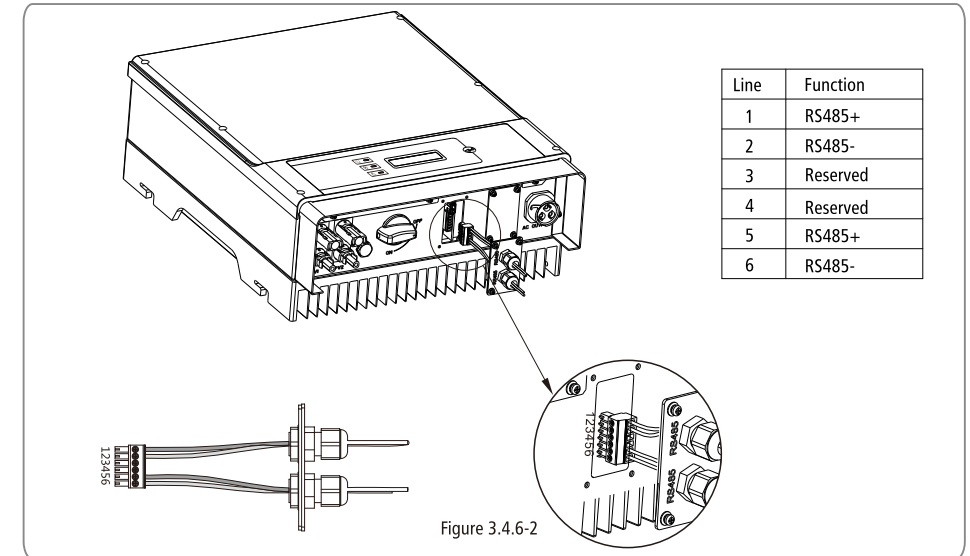

Figure 3.4.6-2

(2) Connect the inverter to EzLogger Pro with RS485 cable, and EzLogger Pro to network switch or router with CAT5E STP cable.

3.4.7 Wi-Fi Communication

The Wi-Fi communication function is only applied to WiFi BOX, the detailed configuration instruction can be referred to Wi-Fi Configuration in the accessory box.

After configuration, please browse <http://www.goodwe-power.com> to create PV station.

3.4.8 Power Limiting Device & DRED Installation

Connection method of Power Limiting device CT please refer to Figure 3.4.8-1.

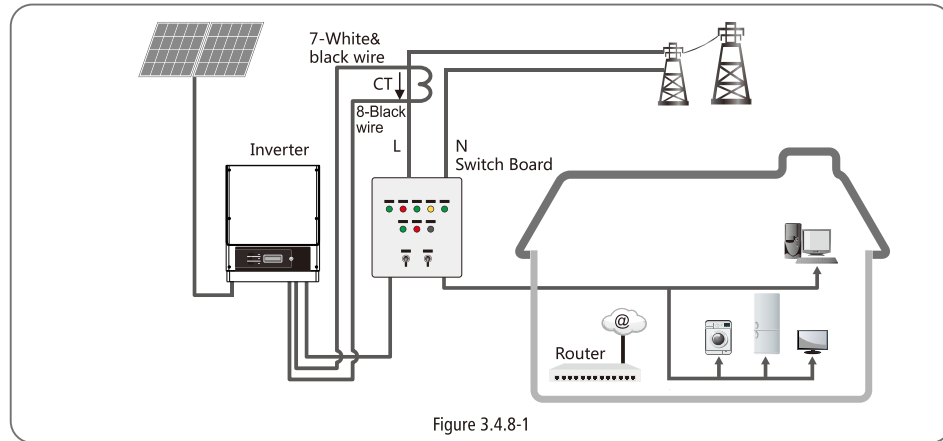

Figure 3.4.8-1

NOTE:

2-pin terminal is used to make connection to CT device. You can find it in accessory bag.

6-pin terminal is used to make connection to DRED device. If DRED device is not available, please keep it not connected.

Connection Procedure:

- Put the cable through the components in this order: screw cap, one-hole sealing ring, insulation body and sheet metal parts.
- Pull out the 6-pin terminal from the socket in the cabinet and take off the resistor which is fixed in it. Cable should be connected as Figure 3.4.8-2.
- Insert the green terminal into the corresponding interior terminal of the inverter. Pull cable softly to maintain the cable not to be pulled out.
- Lock the sheet metal parts onto the box and tighten the screw cap.

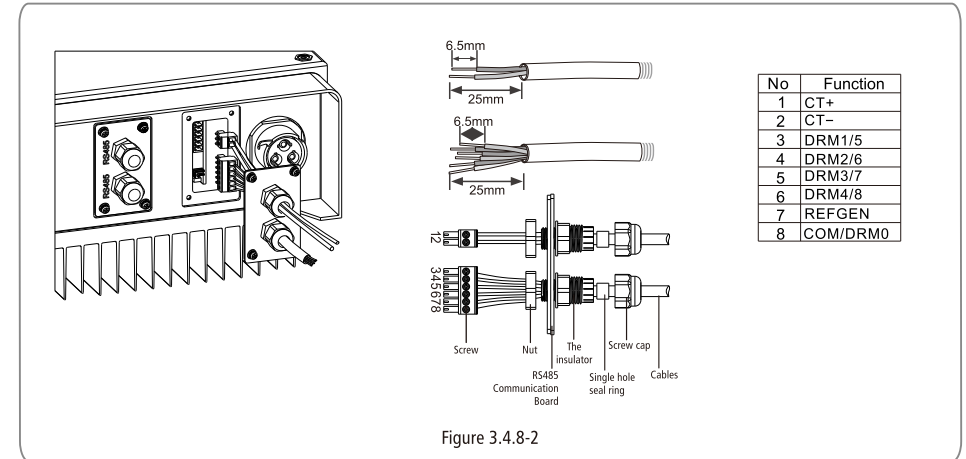

Figure 3.4.8-2

1.DRED connection is only available for Australia and New Zealand

2.Supported DRM command: DRM0,DRM5,DRM6,DRM7,DRM8.

3.After installation is completed, please set up power limiting function referring to section 4.2(6)

4.Pay attention to the direction of CT when wiring. CT clip should be locked tight. White and black cable should connect Line 7 , black cable should connect Line 8. Tighten them with screwdriver. Make sure CT cables connected to the right output phase lines of inverter when in use.

5.Without connection of CT, inverter will show "CT Disconnect". If CT is connected reversely, inverter will show "CT Reverse" when it enters into on-grid status .

3.4.9 Earth Fault Alarm

Inverter complys with part2 of IEC62109-2 13.9. When earth fault occurs, the fault indicator LED on front cover will light on and the buzzer in inverter will keep ringing 1 minute and ring again after half an hour unless the fault is eliminated.

4 System Operation

4.1 Indicator Lights



Indicator lights in Yellow/Green/Red correspondently refer to \ominus / \odot / \triangle

POWER \ominus		ON = WIFI CONNECTED / ACTIVE
		BLINK 1 = WIFI SYSTEM RESETTING
		BLINK 2 = WIFI ROUTER PROBLEM
		BLINK 4 = WIFI SERVER PROBLEM
		BLINK = RS485 CONNECTED
		OFF = WIFI NOT ACTIVE
RUN \odot		ON = INVERTER IS FEEDING POWER
		OFF = INVERTER IS NOT FEEDING POWER AT THE MOMENT
FAULT \triangle		ON = FAULT OCCURRED
		OFF = NO FAULT

4.2 User interface and use of the display

Set Safety Country :

If display shows 'Configure Safety', then long press (2S) the key to enter the second level menu. Short press to browse the safety country available. Choose suitable safety country according to the location of installation. The inverter will store the chosen safety country after 20 seconds of no operation.

(1) A schematic of the display screen is shown as below:

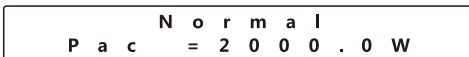

Display area is divided as follows:

Line ①
Line ②

(2) Display area

Line ①---Working status information

- This area displays the status information. "Waiting" indicates the inverter is standby for power generation; "Checking **S" (checking time is based on safety, and varies from country to country) indicates the inverter is self-checking, counting down and preparing for power generation. "Normal" indicates the inverter is generating power. If any condition of the system is abnormal, the screen will display an error message. Refer to Table 4.3.
- Through key operation, the screen can display different information such as operation parameters and power generation status in this area. There are two levels of menus, and the flow chart of first level menu is shown below:

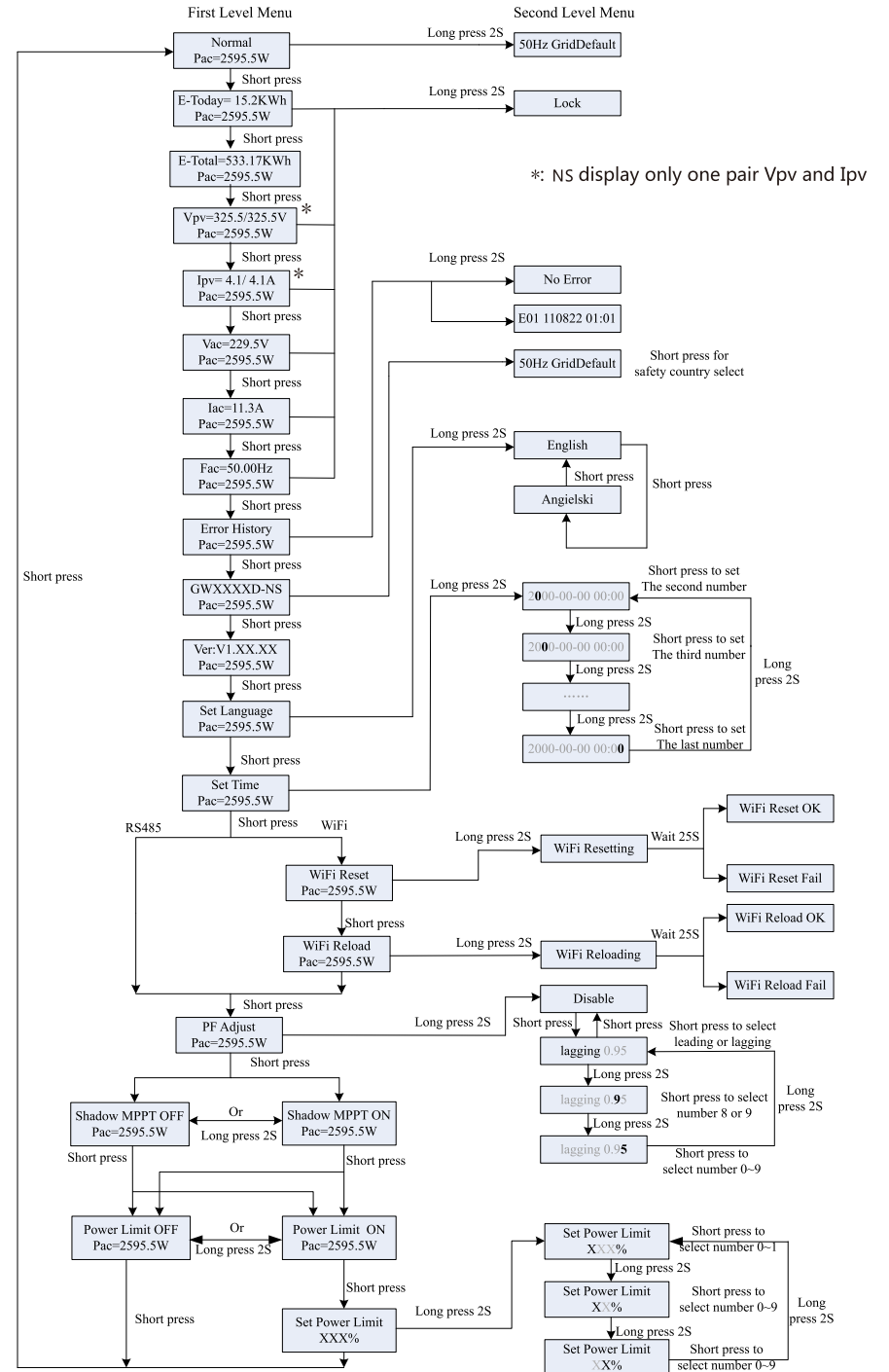

(3) Use of the display

There are 2 modes of button operation: Short press and long press.

(4) Use of the display and LCD display

The display allows accessing the configuration of the basic parameters. All the language, time and country settings can be configured by buttons. The menu, shown in the LCD display area has two levels of menu. Short and long key presses will take you between menus and through each menu. Items in the first level menu that have no second level are locked. For these items, when the key is pressed for two seconds, the LCD will display the word "Lock" followed by data relating to the first level menu item. The locked menu can only be unlocked under system mode switching, fault occurrence or key operation.

In all levels of menu, if no action is taken for 20 seconds, the backlight of the LCD display will switch off, the display will automatically revert to the first item of the first level menu, and any modifications made to the data will be stored into internal memory.

(5) Menu Introduction

- When the PV panel is feeding power to the inverter, the screen shows the first-level menu.
- The initial display is the first item of the first level menu, and the interface displays the current status of the system. It shows "Waiting" in the initial state; it shows "Normal" during power generation mode; if there is something wrong with the system, an error message is shown. Please refer to chapter 5.

View PV voltage, PV current, grid voltage, current and frequency:

- Short press the key to enter the E-Today menu which displays the total power generation for today.
- Short press the key to enter the E-Today menu which displays The total power generation Until today.
- Short press the key to enter the Vpv menu which displays the PV voltage in "V".
- Short press the key to enter the Ipv menu which displays the PV current in "A".
- Short press the key to enter the Vac menu which displays the grid voltage in "V".
- Short press the key once more to enter the Iac menu which displays the grid current in "A".
- Short press the key once more to enter the Frequency menu which displays the grid frequency in "Hz".

●View Error code

Short press the key once more to enter the Error Code History menu.

Long press (2S) the key to enter the second level menu of error detection. The last three inverter error records will be shown by short pressing the key in this second level menu. The records include error codes (EXX) and error times (110316 15:30). Error codes and their related faults can be found in Table 4.3.

●View model name and reconfigure safety country:

From the error code history item in the first level menu, short press the key once to see model name.

If you want to change the safety country, please hold the key for 2 seconds, then the LCD screen will go to the second level menu.

In the second level menu, short press the key can change the safety country.

After choosing the suitable safety country, the inverter will store the chosen safety country if no operation within 20 seconds.

If there is no EXACTLY proper country code, please choose '50Hz Grid Default' or '60Hz Grid Default' accordingly.

●View software version

From the model name item in the first level menu, short press the key once to see software version.

The current software version can be shown in this menu.

Settings:

●Set language:

Short press the button to enter the Set Language menu. Long press (2S) the key to enter the second level menu. Short press to browse the languages available. The inverter will store the chosen language after 20 seconds of no operation.

●Set time:

From the first level Set Language menu, short press the key to enter the Set Time menu.

Long press (2S) the key to enter the second level menu. The initial display is "2000-00-00 00:00", in which the first four numbers represent the year (e.g. 2000~2099); the fifth and sixth numbers represent the month (e.g. 01~12); the seventh and the eighth numbers represent the date (e.g. 01~31). The remaining numbers represent the time.

Short press to increase the number in current location, and long press to move the cursor to next position. The inverter will store

the time after 20 seconds without any key operation, and the LCD will automatically return to the main menu and the backlight will switch off.

●Set protocol:

The function is only used for service personnel, set wrong protocol could lead to communication failure.

From the first level Set Time menu, short press the key once to enter set protocol display menu. Press the key for 2S to enter submenu. The circulatory submenu including two protocols can be found. The protocol can be chosen by short pressing the key. The inverter will store the chosen protocol without any action within 25S and LCD display will automatically return to main menu when the backlight is off.

●MPPT function for Shadow:

The default setting for shadow optimizer is disabled.

Please enable shadow optimizer when there is shadow on PV panel. The function could help the system generate more power under shadow condition.

Please do not enable the function when there's no shadow on panel. Otherwise it could lead to generate less power.

Press the key until enter Shadow Optimize menu. When it shows "Shadow MPPT OFF", it means the MPPT function for shadow is switched off. Press the key 2S to enable the function. If it shows "Shadow MPPT ON" it means the shadow optimizer is on. Press the key 2S to disable the function.

●70% Rated power limit.

The function could only be available for inverter in German. It could only be used by network operator. Otherwise it will cause the PV plant generated reduced.

Press the key until enter 70% rated power menu. If it shows "70% Rated Enable" it means the function to limit the inverter working under 70% rated output is switched off. Pressing key 2S will switch this function on. If it shows "Recover Rated Power" it means inverter is working under 70% of rated output power. Press key 2S will recover inverter to 100% of its rated output power.

(6) Power limiting function setting

The Operations that the ON/OFF of power limiting function (the default is OFF) and the power limiting settings (the default is 2% Rated) are shown below:

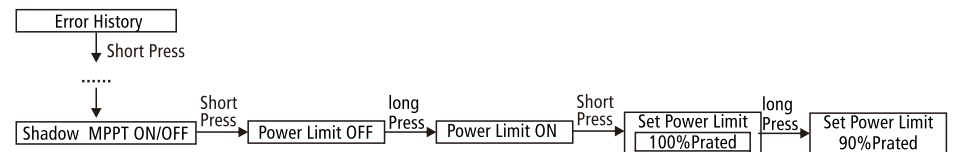

Note If the power limiting function is ON, the maximum output power of the inverter will be limited at the power limiting setting value while the inverter is without the power limiting device(such as a CT/Meter) or the power limiting device is out of work.

(7) Operation of Display when commissioning.

When the input voltage reaches the inverter turn-on voltage, the LCD starts to work, the yellow light is on and the LCD displays "Waiting". More information will be displayed within a few seconds. If the inverter is connected to the grid, "Checking 30" will be displayed and a countdown will commence from 30 seconds. When it shows "00S" you will hear the relay triggered 4 times. The LCD will then display "Normal". The instant power output will be shown at the left bottom of the LCD.

4.3 Error code

An error message will be displayed on the LCD if a fault occurs.

Error Code	Error message	Description
03	Fac Fail	Grid frequency out of permissible range
14	Isolation Fail	Grund insulation impedance is too low
15	Vac Fail	Grid voltage out of permissible range
17	PV Over Voltage	Overvoltage at DC input
19	Over Temperature	Over temperature on the case
23	Utility Loss	Utility is unavailable

4.4 Wi-Fi Reset & Wi-Fi Reload

The two functions are only available for Wi-Fi model inverters.

Wi-Fi reload function is used to change the Wi-Fi configuration to default value. Please configure the Wi-Fi again as 3.4.5 after using the function.

Press the key until the LCD displays “Wi-Fi Reset”, then long press (2S) until the LCD displays “Wi-Fi Resetting...”. Stop pressing and wait for the screen showing “Wi-Fi Reset OK” or “Wi-Fi Reset Failed”.

Press the key until the LCD displays “Wi-Fi Reload”, then long press (2S) until the LCD displays “Wi-Fi Reloading...”. Stop pressing and wait for the screen showing “Wi-Fi Reload OK” or “Wi-Fi Reload Failed”.

5 Troubleshooting

In most situations, the inverter requires very little maintenance. However, if the inverter is not working properly, please try the following troubleshooting solutions:

●When a problem occurs, the red (fault) LED indicator on the front panel will light up and the LCD screen will display the type of fault. The following table lists error messages and the solutions for associated faults.

Display		Troubleshooting
System failure	Isolation Fail	1.Disconnect DC switch, take off DC connector, Check the impedance between PV (+) & PV (-) to earth. 2.If impedance is less than 100 kΩ, please check the insulation of PV string wiring to the earth. 3.If impedance is larger than 100 kΩ, please contact local service office. 4.Take off AC connector, measure the impedance between neutral and PE. If it is larger than 10 kΩ, please check AC wiring.
	Ground I Fail	1.Disconnect DC switch, check the insulation of PV string wiring to earth. 2.Reconnect the DC switch again. 3.If the problem still exists, please call the local service office.
	Vac Fail	1.Disconnect the DC switch, taking off AC connector, measuring the voltage between line and neutral in connector, make sure if it conforms to the grid-connected specification of inverter. 2.If it does not, please check grid wiring. 3.If it does, please connect AC connector, reconnect DC switch, inverter will connect grid automatically. If the problem still exists, please call the local service office.
	Fac Fail	1.The PV Inverter will automatically restart if the Fac returns to normal. 2.If the problem still exists, please call the local service office.
	Utility Loss	1.Disconnect the DC switch, taking off AC connector, measure the voltage between line and neutral n connector, make sure if it conforms to the grid-connected specification of inverter. 2.If it does not, please check if the distribution switch is connected and the grid is normal. 3.If it does, reconnect AC connector and DC connector; If the problem still exists, please call the local service office.

Display		Troubleshooting
System failure	PV Over Voltage	1.Disconnect the DC switch, take off DC connector, check PV string voltage, make sure if it exceeds the input voltage in inverter specification. 2.If it does, please reconfigure PV panel string. 3.If the problem still exists, please call the local service office.
	Over Temperature	1.Please check if installation position conforms to the specification. 2.Try to lower the surrounding temperature. 3.Move the inverter to vents or alter the installation position. 4.If the problem still exists, please call the local service office.
Inverter failure	Relay-Check Fail	1.Disconnect the DC connector. 2.Reconnect the DC connector. 3.If the problem still exists, please call the local service office.
	DCI High	
	EEPROM R/W Fail	
Inverter failure	SPI Fail	1.Disconnect the DC connector. 2.Reconnect the DC connector. 3.If the problem still exists, please call the local service office.
	DC Bus High	
	GFCI Fail	
	No display	1.Disconnect the DC switch, take off DC connector, measure the voltage of PV string. 2.Plug in DC connector, and reconnect DC switch. 3.If the voltage is less than 70V, please check the PV string configuration. 4.If the voltage is higher than 125V and still no display, please contact local service office.

Note: When sunlight is insufficient, the PV Inverter may continuously start up and shut down automatically due to insufficient power generated by the PV panels, which would not lead to inverter damage. If the problem still exists, please call the local service office.

6 Technical Parameters

Model	GW1000-NS	GW1500-NS	GW2000-NS	GW2500-NS	GW3000-NS
DC input Data					
Max. DC power(W)	1200	1800	2300	2700	3200
Max. DC voltage (V)	500	500	500	500	500
MPPT voltage range (V)	80~450	80~450	80~450	80~450	80~450
Starting voltage (V)	80	80	80	80	80
Max. DC current (A)	10	10	10	18	18
DC overcurrent protection(A)	12.5	12.5	12.5	22.5	22.5
No. of DC connectors	1	1	1	1	1
No. of MPPTs	1	1	1	1	1
DC overvoltage category	Category II				
DC connector	AMPHENOL H4/ MC4 /SUNCLIX(optional)				
AC Output Data					
Norminal AC power(VA)	1000	1500	2000	2500	3000*
Max. AC power(VA)	1000	1500	2000	2500	3000
Max. AC current(A)	5	7,5	10	12.5	13.5

Model	GW1000-NS	GW1500-NS	GW2000-NS	GW2500-NS	GW3000-NS
AC overcurrent protection(A)	7	11	15	19	20
Nominal AC output	50/60Hz; 220/230Vac				
AC output range	45~55Hz/55~65Hz; 180~270Vac				
THDi	<3%				
Power factor	0.8 leading~0.8 lagging				
Grid connection	Single phase				
AC overvoltage category	Category III				
Efficiency					
Max. efficiency	96.2%	96.2%	96.2%	97.2%	97.2%
Euro efficiency	>96.0%	96.0%	>96.0%	>97.0%	>97.0%
MPPT adaptation efficiency	>99.9%				
Protection					
Residual current monitoring unit	Integrated				
Active anti-islanding protection	Active Frequency Disturbance and Reactive Power Disturbance				
DC switch	Integrated (optional)				
AC over current protection	Integrated				
Insulation monitoring	Integrated				
Certifications&Standards					
Grid regulation	G83/2,VDE0126-1-1,AS4777.2&.3,EN50438,ERDF-NOI-RES_13E				
Safety	According to IEC62109-1&-2				
EMC	EN 61000-6-1, EN 61000-6-2, EN 61000-6-3, EN 61000-6-4, EN 61000-3-2, EN 61000-3-3				
General Data					
Dimensions (WxHxD)	344*274.5*128mm				
Weight (kg)	7.5		8.5		
Mounting	Wall bracket				
Ambient temperature range	-25~60°C (>45°C derating)				
Relative humidity	0~95%				
Moisture location category	4K4H				
Max. operating altitude	4000m(>2000m derating)				
Protection degree	IP65				
Environment category	Outdoor & indoor				
External environment pollution degree	Grade1、2、3				
Topology	Transformerless				
Night power consumption(W)	<1				
Cooling	Nature convection				
Noise emission(dB)	<25				
Display	LCD				
Communication	WiFi or RS485				
Standard warranty(years)	5/10/15/20/25 (optional)				

* 3200 for Thailand PEA, 3000 for other countries.

Model	GW3600-NS	GW4200-NS	GW5K-NS	GW5000-NS
DC input Data				
* Max. DC power(W)	4680	5460	6500	6500
Max. DC voltage (V)	580	580	580	580
MPPT voltage range (V)	80~550	80~550	80~550	80~550
Starting voltage (V)	120	120	120	120
Max. DC current (A)	22	22	22	22
DC overcurrent protection(A)	27.5	27.5	27.5	27.5
No. of DC connectors	2	2	2	2
No. of MPPTs	1	1	1	1
DC overvoltage category	Category II			
DC connector	AMPHENOL H4/ MC4 /SUNCLIX(optional)			
AC Output Data				
Norminal AC power(VA)	3680	4200	4600	5000*
Max. AC power(VA)	3680	4200	4950	5000*
Max. AC current(A)	16	19	21.7	22.8**
AC overcurrent protection(A)	24	29	35	35
Norminal AC output	50/60Hz; 220/230Vac			
AC output range	45~55Hz/55~65Hz; 180~270Vac			
THDi	<3%			
Power factor	0.8 leading~0.8 lagging			
Grid connection	Single phase			
AC overvoltage category	Category III			
Efficiency				
Max. efficiency	97.8%	97.8%	97.8%	97.8%
Euro efficiency	97.5%	97.5%	97.5%	97.5%
MPPT adaptation efficiency	99.9%			
Protection				
Residual current monitoring unit	Integrated			
Active anti-islanding protection	Active Frequency Disturbance and Reactive Power Disturbance			
DC switch	Integrated (optional)			
AC over current protection	Integrated			
Insulation monitoring	Integrated			
Certifications&Standards				
Grid regulation	VDE-AR-N 4105, AS4777.2&.3, RD1699, IEC62109-2/1, VDE0126-1-1+A1, EN50438 G83/G59			
Safety	IEC62109-1&-2, AS3100			
EMC	EN 61000-6-1,EN 61000-6-2,EN 61000-6-3,EN 61000-6-4, EN 61000-3-11, EN 61000-3-12			

* 4600 VDE-AR-N4105;4950 for Australian;5000 for other country.

** 22.8 for other country;21.7 for Australian.

Model	GW3600-NS	GW4200-NS	GW5K-NS	GW5000-NS
General Data				
Dimensions (WxHxD)	347*432*145mm			
Weight (kg)	14			
Mounting	Wall bracket			
Ambient temperature range	-25~60°C (>45°C derating)			
Relative humidity	0~95%			
Moisture location category	4K4H			
Max. operating altitude	4000m(>3000 derating)			
Protection degree	IP65			
Environment category	Outdoor & indoor			
External environment pollution degree	Grade1、2、3			
Topology	Transformerless			
Night power consumption(W)	<1			
Cooling	Nature convection			
Noise emission(dB)	<25			
Display	LCD			
Communication	RS485 or WiFi			
Standard warranty(years)	5/10/15/20/25 (optional)			

Model	GW3000D-NS	GW3600D-NS	GW4200D-NS	GW5KD-NS	GW5000D-NS
DC input Data					
* Max. DC power(W)	3900	4680	5460	6500	6500
Max. DC voltage (V)	580	580	580	580	580
MPPT voltage range (V)	80~550	80~550	80~550	80~550	80~550
Starting voltage (V)	120	120	120	120	120
Max. DC current (A)	11 / 11	11 / 11	11 / 11	11 / 11	11 / 11
DC overcurrent protection(A)	13.8/13.8	13.8/13.8	13.8/13.8	13.8/13.8	13.8/13.8
No. of DC connectors	2	2	2	2	2
No. of MPPTs	2(can parallel)	2(can parallel)	2(can parallel)	2(can parallel)	2(can parallel)
DC overvoltage category	Category II				
DC connector	AMPHENOL H4/ MC4 /SUNCLIX(optional)				
AC Output Data					
Normal AC power(VA)	3000	3680	4200	4600	5000*
Max. AC power(VA)	3000	3680	4200	4950	5000*
Max. AC current(A)	13.6	16	19	21.7	22.8**
AC overcurrent protection(A)	20	24	29	35	35
Normal AC output	50/60Hz; 220/230Vac				
AC output range	45~55Hz/55~65Hz; 180~270Vac				
THDi	<3%				
Power factor	0.8 leading~0.8 lagging				
Grid connection	Single phase				

Model	GW3000D-NS	GW3600D-NS	GW4200D-NS	GW5KD-NS	GW5000D-NS
AC overvoltage category	Category III				
Max. efficiency	97.8%	97.8%	97.8%	97.8%	97.8%
Euro efficiency	97.5%	97.5%	97.5%	97.5%	97.5%
MPPT adaptation efficiency	>99.9%				
Protection					
Residual current monitoring unit	Integrated				
Active anti-islanding protection	Active Frequency Disturbance and Reactive Power Disturbance				
DC switch	Integrated (optional)				
AC over current protection	Integrated				
Insulation monitoring	Integrated				
Certifications&Standards					
Grid regulation	VDE-AR-N 4105, AS4777.2&.3, RD1699, IEC62109-2/1, VDE0126-1-1+A1, EN50438 G83/G59				
Safety	IEC62109-1&-2, AS3100				
EMC	EN 61000-6-1,EN 61000-6-2,EN 61000-6-3,EN 61000-6-4, EN 61000-3-11, EN 61000-3-12				
General Data					
Dimensions (WxHxD)	347*432*145mm				
Weight (kg)	14				
Mounting	Wall bracket				
Ambient temperature range	-25~60°C (>45°C derating)				
Relative humidity	0~95%				
Moisture location category	4K4H				
Max. operating altitude	4000m(>3000 derating)				
Protection degree	IP65				
Environment category	Outdoor & indoor				
External environment pollution degree	Grade1、2、3				
Topology	Transformerless				
Night power consumption(W)	<1				
Cooling	Nature convection				
Noise emission(dB)	<25				
Display	LCD				
Communication	WiFi or RS485				
Standard warranty(years)	5/10/15/20/25 (optional)				

* 4600 VDE-AR-N4105;4950 fro Australian;5000 for other country

** 22.8 for other country;21.7 fro Australian

** : Please make sure the voltage of PV string will not exceed the Max. DC voltage.

Note

Overvoltage category definition

Category I : applies to equipment connected to a circuit where measures have been taken to reduce transient overvoltage to a low level.

Category II : applies to equipment not permanently connected to the installation. Examples are appliances, portable tools and other plug-connected equipment;

Category III: applies to fixed equipment downstream of and including, the main distribution board. Examples are switchgear and other equipment in an industrial installation;

Category IV: applies to equipment permanently connected at the origin of an installation (upstream of the main distribution board). Example are electricity meters, primary overcurrent protection equipment and other equipment connected directly to outdoor open lines.

Moisture location category definition

Moisture parameters	Level		
	3K3	4K2	4K4H
Temperature Range	0~+40°C	-33~+40°C	-20~+55°C
Humidity Range	5%~85%	15%~100%	4%~100%

Environment category definition

Outdoor : the ambient air temperature is -20~50°C, Relative humidity range is 4 % to 100 %, applied to PD3

Indoor unconditioned: the ambient air temperature is -20~50°C, Relative humidity range is 5 % to 95%, applied to PD3

Indoor conditioned: the ambient air temperature is 0~40°C, Relative humidity range is 5 % to 85%, applied to PD2

Pollution degree definition

Pollution degree 1: No pollution or only dry, non-conductive pollution occurs. The pollution has no influence.

Pollution degree 2: Normally only non-conductive pollution occurs. Occasionally, however, a temporary conductivity caused by condensation must be expected.

Pollution degree 3: Conductive pollution occurs, or, dry, non-conductive pollution occurs which becomes conductive due to condensation which is expected.

Pollution degree 4: Persistent conductive pollution occurs, for example, the pollution cause by conductive dust, rain and snow.

7 Certificates



IEC62109-2 VDE0126-1-1